

A whole house fan is a simple and inexpensive method of cooling a house. From a heating and cooling standpoint, it has advantages and disadvantages. Unless the area above it is sealed properly, it can be an area with significant energy loss.

The advantage of a whole house fan is that it draws cool outdoor air inside through open windows and exhausts hot room air through the attic to the outside. The result is lower indoor temperatures and improved evaporative cooling.

The disadvantage is that it can only cool the inside of a house to the outside temperature. Unlike an air conditioner, it does not dehumidify, and dust and pollen can be brought into the house.

During the winter months (and summer when air conditioning is used), a whole house fan represents a potential energy loss because it is essentially a large, uninsulated hole in the ceiling. Standard fan louvers do not insulate or seal tightly.

To stop the leak, a cover should be built to airseal and insulate this hole during the seasons when the fan is not in operation. The cover may be installed from the attic side, if attic access is easily available, or from the house side. Both covers could be included in excessively hot or cold climates. Homeowners must remember to remove covers before operating the fan and to replace covers during seasons when the fan is not in use.

A typical whole house fan has a 30-inch diameter blade with an additional inch needed for blade clearance. The box can be built from 4-x-4 pieces of one-inch thick rigid fiberglass duct board. The box will typically be a 33-inch square with 1-inch thick walls and be 6 and one-half inches deep. Measure carefully to make sure the box will fit.

Building the box is not difficult, and it can help tremendously with the energy efficiency of a home by sealing the hole in the ceiling.

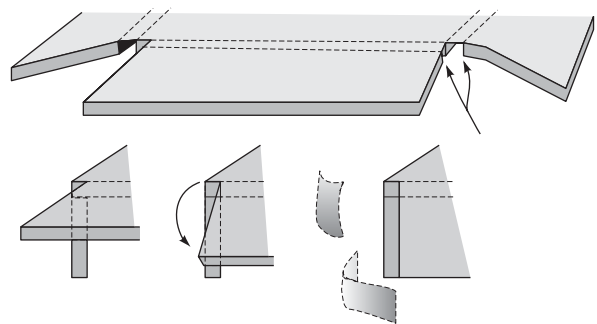
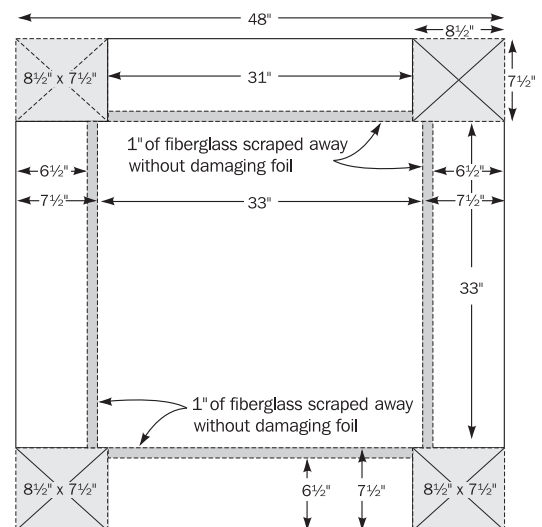

Installing a whole house fan

Use house wrap tape, spray foam, or caulk to seal fan frame to truss frame

Truss chord mounting bracket
Line up brackets
Do not cut truss chord

Airseal any gaps between fan box and truss frame so that when fan is running, no attic air is pulled across the fan.

Construct "H" brackets from 2x4's to create frame support for fan (see detail on next page)

Caulk to seal louver frame flange to ceiling

caulk cracks and seams

IMPORTANT:
Ensure louvers function properly (no binding or sticking)

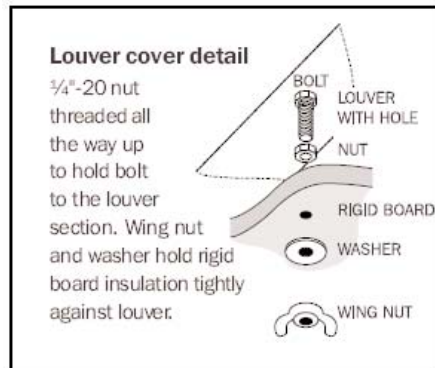

VELCRO™ - Helps to seal and attach cover used in winter

Louver cover materials list:

- 30" x 30" piece of 3/4" - 1" rigid insulation (minimum thickness)
- White contact paper
- Drill with 1/4" bit
- 1 1/4" long, 1/4" - 20 threaded bolt
- Fender washer with 1/4" opening
- 1/4" - 20 wing nut
- VELCRO™ with adhesive fasteners

Mount cover to louver with VELCRO™ and bolt with washer and wing nut

Hole,
Washer,
& Wing nut

Rigid board insulation (3/4" - 1" thick) covered with white contact paper

