

Many Kentucky homes are wasting energy and valuable dollars because of leaks in the duct system.

In forced-air heating and cooling systems, efficiency can be improved by as much as 30 percent by sealing these leaks.

By eliminating leakage in the ducts, the home's heating and air conditioning system can provide comfort with decreased run-time. This will result in lower utility bills and improved air quality. It will also extend the life of the equipment.

In most homes, the ducts are usually located in the attic, crawl space or basement.

Provided the ductwork is accessible, sealing it is a relatively simple procedure and often makes an immediate improvement in the circulation of conditioned air throughout the house.

This is accomplished by applying a substance called mastic with a paintbrush to every duct seam, with special attention paid to the return side of the system.

Mastic is a gray paste-like substance containing fiber, which is easily spread across the seams of the ductwork. It dries to a solid cement-like quality, providing a permanent solution to unwanted leakage on both the return and supply side of the ductwork.

Mastic can be purchased at companies that sell

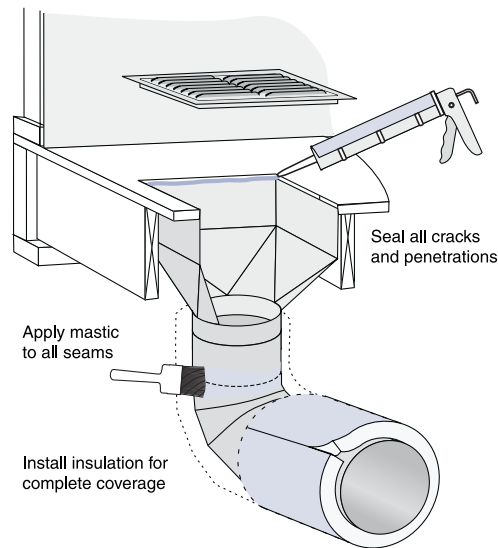

wholesale supplies to heating, ventilation and air conditioning contractors.

Once the leaks are fixed with mastic, additional savings can be achieved by insulating the ducts located in unheated areas with either foil-faced fiberglass duct insulation or foil-faced "bubble wrap." The insulation is simply wrapped around the duct and tied or taped into place.

If the ducts are inaccessible, it's advisable to hire a contractor to conduct a pressure test with a special fan. This "blower door" test can determine if you have serious leakage. Some duct connections simply may have come apart.

In most cases, a little time spent addressing this issue can make a major difference in the energy efficiency of your home.