

A knee wall is a wall that is often located upstairs in a home and has conditioned living space on one side and attic space behind it. It is usually 3 to 5 feet high with the top ending along the roof line.

However, a knee wall is most accurately described as any wall inside living space that backs up to an attic. In larger homes, it is not uncommon to find knee walls that are 10 to 20 feet high in a den or family room.

If not insulated or built properly, however, a knee wall can become a major break in your home's thermal envelope and can cause high monthly bills. Without a proper seal, the extremely hot and cold air of the attic can leak into your living space, resulting in higher electricity usage to heat or cool your home.

Unfortunately, builders often insulate a knee wall with no rigid board covering the wall insulation on the inside of the attic space. Another issue is that the flooring may have an ineffective barrier to the hot and cold attic air.

A very effective step homeowners can take is to nail rigid foam board, drywall or foil-faced hardboard to the studs. Nail this material on top of the insulation inside the attic space and cover the R-13 insulation completely. Tape each seam and place a bead of caulk or expanding foam along the top and bottom plates.

Also, if you can access the attic floor between the joists, make the area below the bottom plate air-tight so that cold or hot attic air does not leak under the floor of the living space. Foam board

pieces should be cut and fit into each cavity between joists and then sealed with caulk or expanding foam.

The key concept is to keep the home's thermal envelope intact. Heat always seeks cold in nature. That's why it is important to have a good thermal barrier that keeps extremely hot or cold air out of living space.

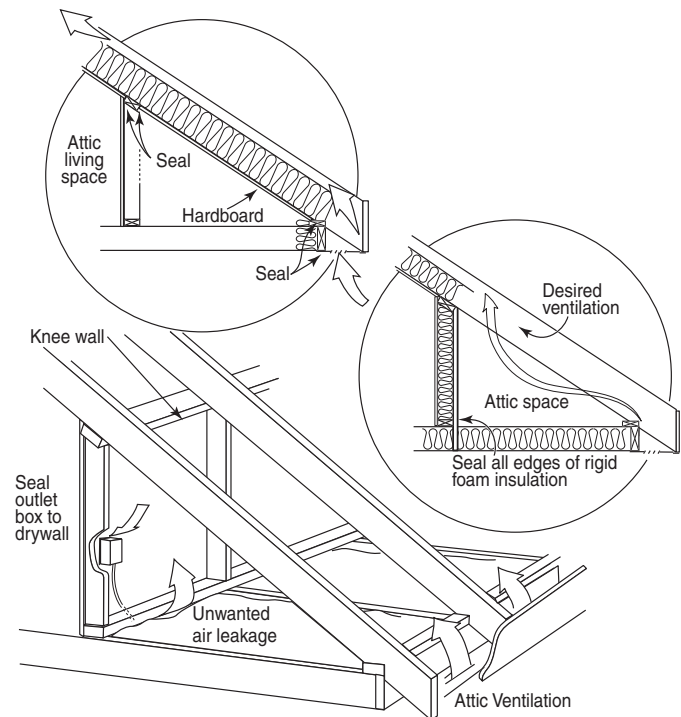

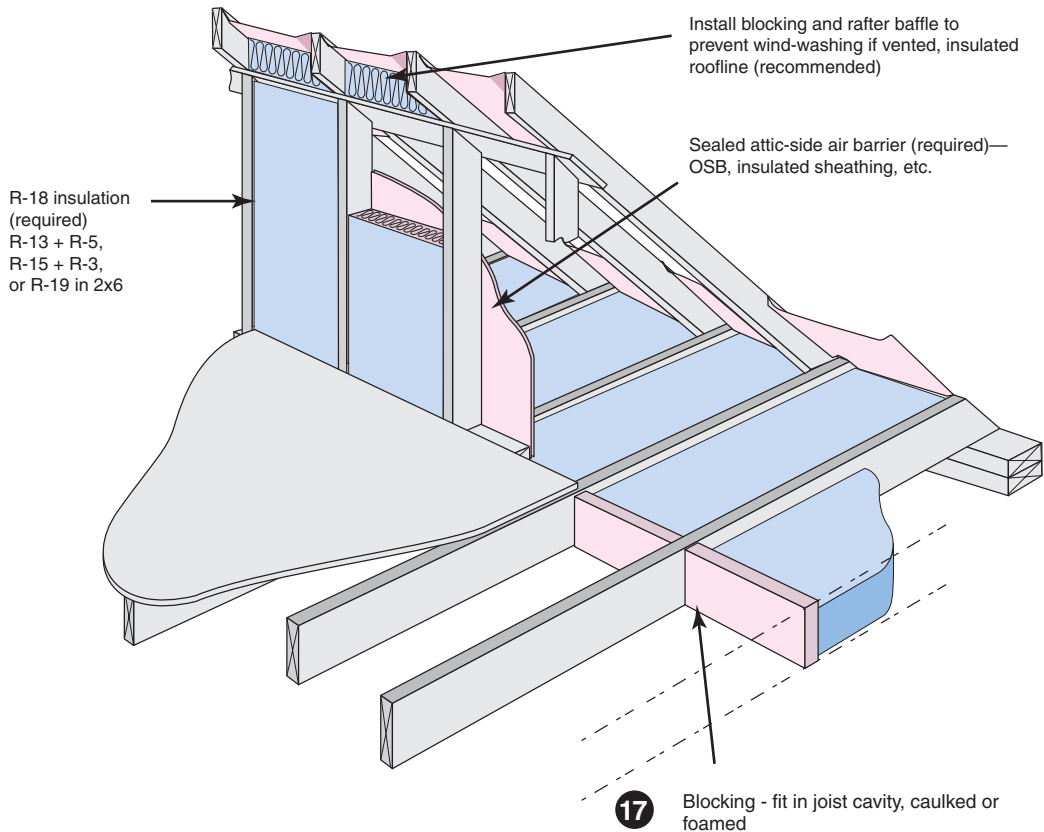

Attic knee-walls

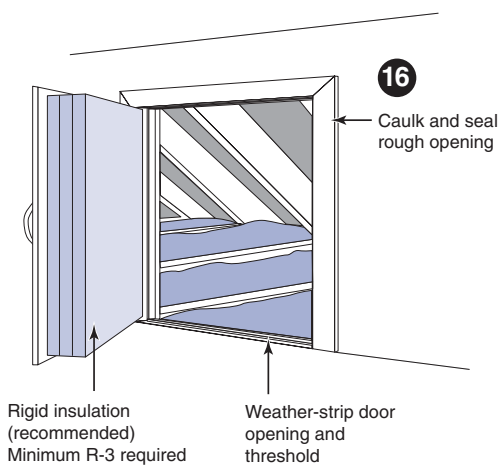

Two-level attic

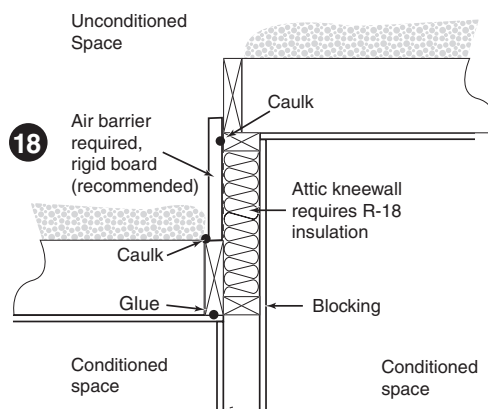

Disclaimer:
This document is intended solely to help graphically demonstrate the air leakage provisions of section 402.4 of the 2006 IECC. It does not cover all airsealing locations or techniques. Other code provisions may be applicable as well.