

Most building codes require roof vents because the increased airflow expels moisture that can degrade insulation. In hot weather, proper ventilation reduces roof temperatures, which saves on cooling costs and lengthens the life of your roof.

A continuous ridge vent along the peak of your roof, combined with soffit vents at the eave, will provide the most effective ventilation.

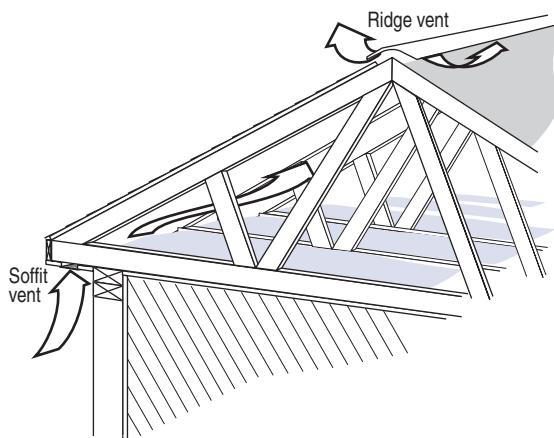

The vented area should be divided equally between the ridge and soffits.

If your home has insufficient ridge venting, cap vents, turbines and gable vents can supplement your roof design.

Power roof ventilators are not recommended because of the energy consumption, and the units also create negative pressure that may pull conditioned room air into your attic.

A common problem occurs at the eave. Many roof designs leave insufficient space for full insulation without blocking airflow from the soffit vents. Compressed insulation is much less effective.

In stick-built roofs, where rafters and ceiling joists are cut and installed on the construction site, an additional top plate that lays across the top of the ceiling joists at the eave will prevent compression of the attic insulation and also allow for ventilation.

Federal housing officials recommend one square foot of attic ventilation (both intake and exhaust) for every 300 square feet of attic space. For example, if your attic is 900 square feet, you need a total of 3 square feet of ventilation. This amount is usually evenly divided between intake and exhaust. Your energy advisor can help you to assess whether you have adequate ventilation and offer tips on how to correct typical attic ventilation problems.

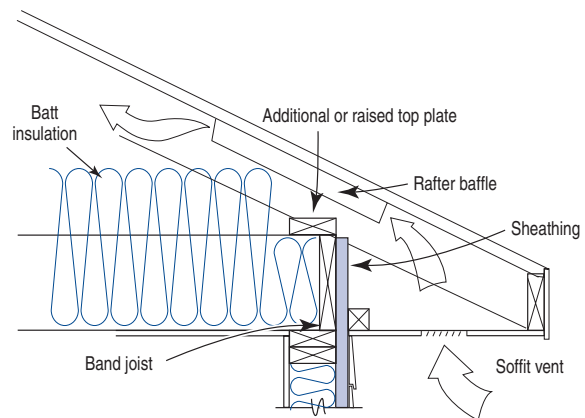

**A raised top plate increases the area for insulation and ventilation at the eaves.**