

One common type of access to the attic that can cause higher monthly bills is the pull-down attic stairs.

If pull-down stairs are not sealed properly, extremely hot or cold air from the attic can infiltrate into the home. In a typical 1,000-square-foot home, a poorly sealed pull-down attic stairway could reduce the effectiveness of the attic insulation by as much as 30 percent.

The good news is that this problem can be eliminated with little effort.

The frame for the pull-down stairs fits into a rough opening and rests upon a flat panel that is on the living-space side.

If there is a gap on the end where the hinges are located, the gap must be sealed. If the gap is less than one-half inch, you can apply caulk to seal. If a larger opening exists, non-expanding foam or a backing material (backer rod) is recommended in conjunction with caulk.

Be careful if using expanding foam to seal this gap. Because the material can easily expand (often more than people think), make sure it does not interfere with the ability of the stairs to open or close.

To ensure a tight fit, add weather-stripping where the flat panel fits against the ceiling. Adding a latch bolt on the living space side ensures a tighter seal.

Finally, it's extremely important to add a light-weight attic stair cover box made from rigid insulation above the top of the stairs. The box rests above the stairs on the attic side. The box is simply pushed aside to gain attic access. For details on constructing this box, see the illustration on back.

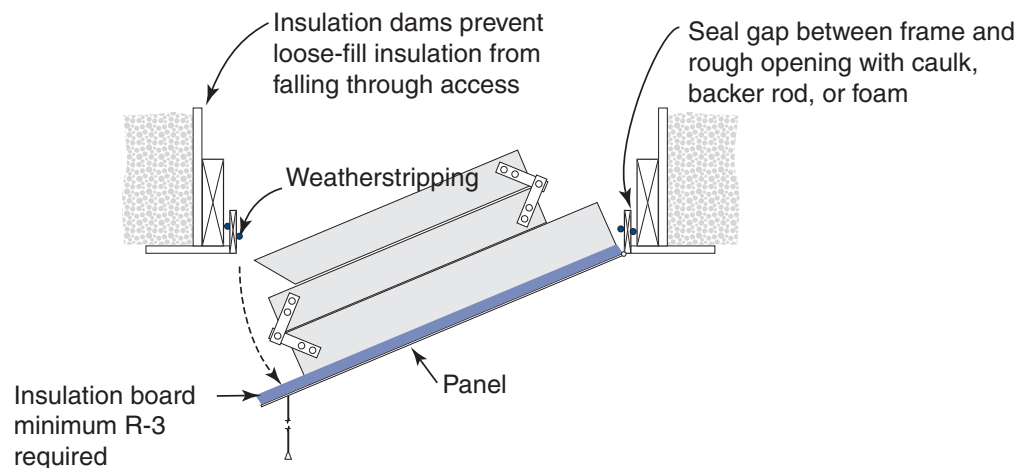

Construct an Attic Stairs Cover Box

Use the template shown here to cut pieces from a single 4'x8' sheet of ½-inch rigid insulation. Be sure to carefully measure both inside and outside dimensions to the appropriate length, width, and depth clearances for the cover box.

Create the box as shown: Apply adhesive/mastic and use roofing nails to construct the two end and two side pieces. Assemble the side and end pieces into a box using adhesive and longer nails. Add the center support brace and cover piece with glue and nails. A faced insulation batt can be glued to the cover piece with adhesive applied to the paper backing.

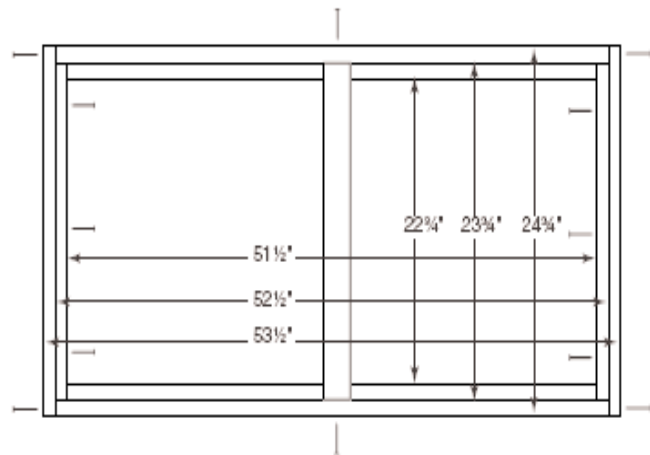

Assemble side pieces, end pieces, and brace as shown. The cover piece will drop in and be attached with adhesive and nails.

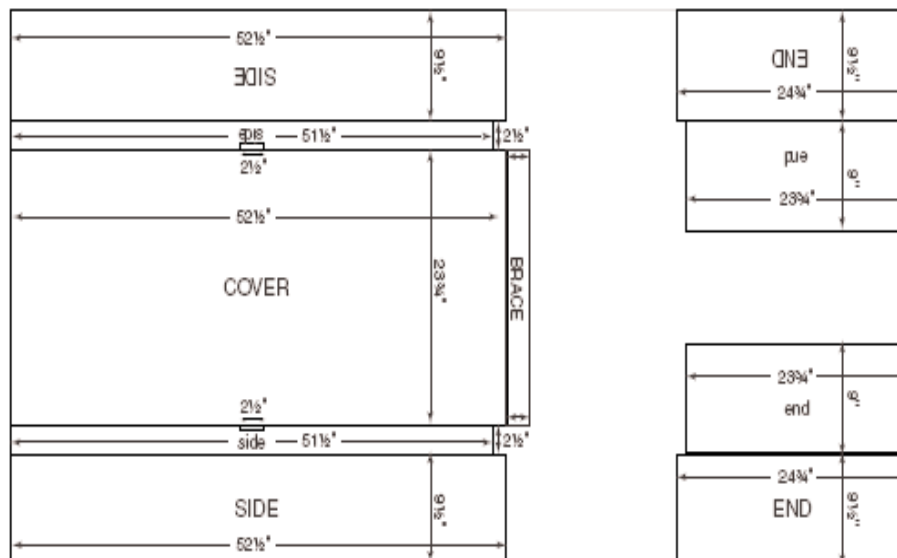

Dimensions shown are for a box 53½" outside (51½" inside), 24¾" outside (22¾" inside), and 9" of depth inside. Adjust dimensions to fit the specific stairs being installed.

Materials needed:

- Rigid Insulation such as ½-inch extruded polystyrene
- Fiberglass batt (optional)
- Duct sealing mastic or construction adhesive
- 1" roofing nails, 8d or 16d nails
- Tape measure, sharp utility knife, and straight-edge; or table/circular saw
- Weatherstripping/gasket material with adhesive